

YEAR 11 CHEMISTRY

WEEK 2

WORKSHEET 1

- Which of the following measurements has 3 significant figures?
A. 150 B. 25.0 C. 135.0 D. 80.17
- Which of the following is the correct unit for concentration?
A. g B. m^3 C. Pa D. g L^{-1}
- The measuring instrument used for transferring and measuring small volumes of liquids accurately is a
A. beaker. B. pipette. C. standard flask. D. measuring cylinder.
- State the importance of the following:
 - Students must never play while working in the laboratory.
 - Rinsing all glassware well before use.
- During your chemistry classes, you have used the following apparatus.

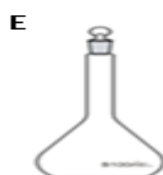
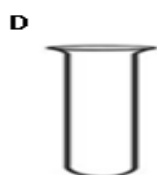
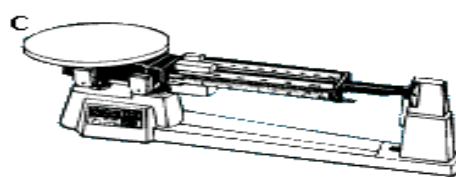

- Name all the apparatus illustrated above.
 - State the uses for apparatus **A** and **G**.
- State **one use** of the following apparatus in the laboratory.
 - Separating funnel
 - Measuring cylinder
 - Laboratory procedures are always converted to past participle and then written in reports. Convert the following to past participle.

Add 20 mL of water to a test tube and place a small piece of magnesium ribbon in it.

8. Large volumes of liquid can be measured using a measuring cylinder.

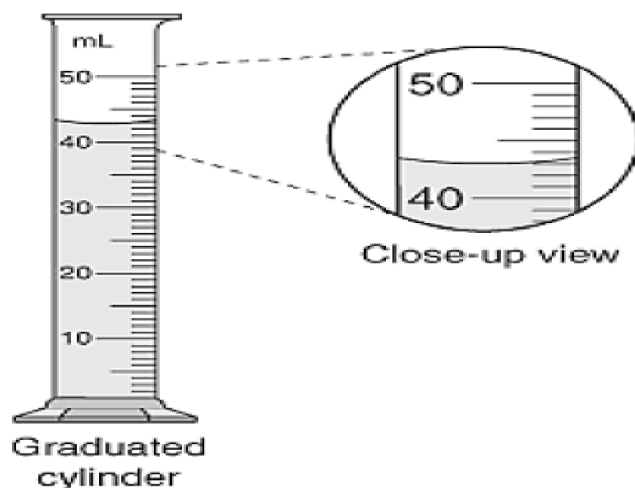

Determine the volume of liquid shown in the measuring cylinder above.

9. Study the heating curve of water and answer the questions that follow.

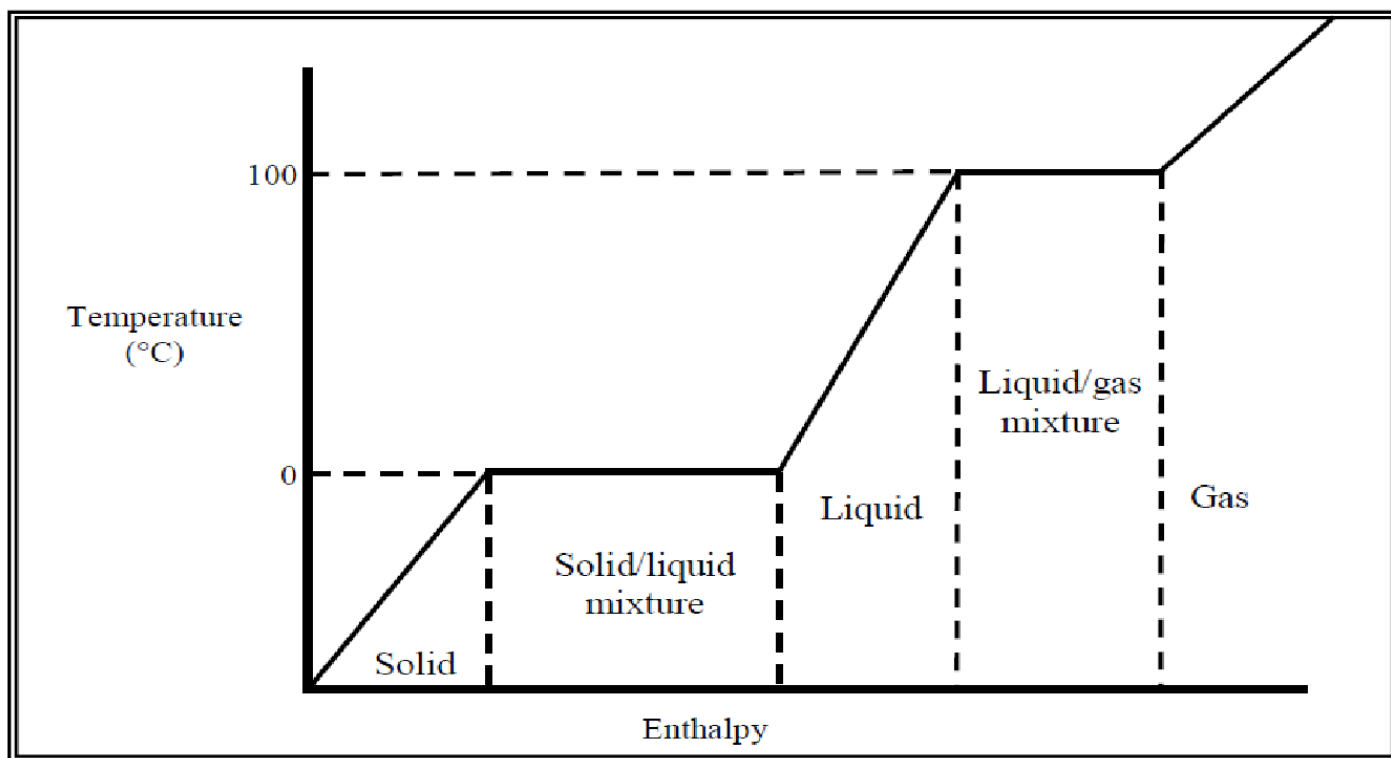

- Describe the process that is occurring at the liquid/gas mixture phase of water.
- Briefly explain why the process of water changing from its solid to liquid phase cannot be classified as a chemical change?

10. Explain why it is important to have the meniscus at eye level when reading a burette.

11. Perform the following calculation to the correct number of significant figures:

$$0.5 \text{ m} \times 20.5 \text{ m} \times 7.5 \text{ m}$$

1. The correct number of significant figures in 2.300 is

- A. 1 B. 2 C. 3 D. 4

2. Which of the following statements is **true** regarding the two isotopes of chlorine,

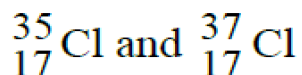

The number of 35 17 37 17

- A. protons in each isotope is different. B. neutrons in each isotope is the same.
C. electrons in each isotope is different. D. neutrons in each isotope is different.

3. Which of the following properties best describes an ionic compound?

- A. They usually have high melting points.
B. They are highly soluble in all organic solvents.
C. They usually have low melting and boiling points.
D. They are good conductors of electricity in solid state.

4. Which of the following elements has the highest electronegativity?

- A. Boron B. Oxygen C. Fluorine D. Nitrogen

5. According to the Law of Definite Composition,

- A. the total mass after a chemical change is the same as before the change.
B. the ratio of the masses of the elements in a compound is always the same.
C. it is not possible for the same two elements to form more than one compound.
D. the same two elements form two different compounds in the same ratio.

6. The knowledge gained through the study of Chemistry opens many career pathways.

i) Name **two** careers that require knowledge of Chemistry.

ii) Give **one** example of a chemical based industry in Fiji.

7. The diagram below shows a method used by some Year 11 students for determining the volume of an irregular solid.

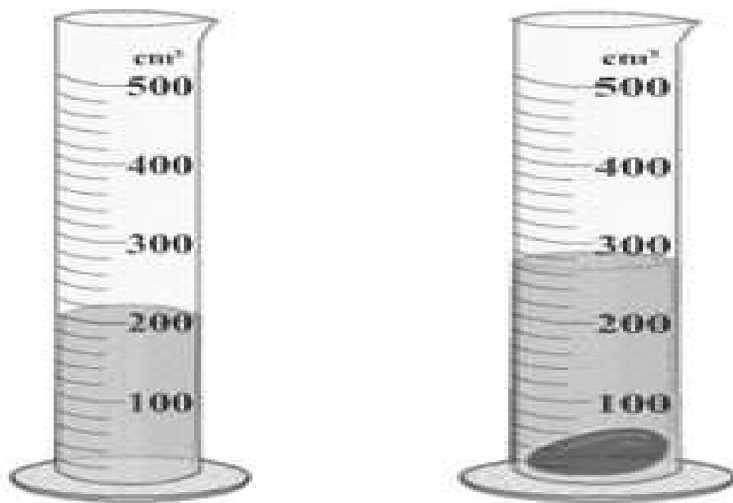

i) Complete the missing Step 4 that needs to be followed to conduct the above experiment successfully.

1. Partially fill a measuring cylinder with water and note the volume.

2. Place the solid in the measuring cylinder without splashing the water.
3. Note the new volume of water in the measuring cylinder.
4. _____.

ii) After determining the volume, the students measured the mass of the solid without drying it first. Explain why will this affect the density calculations.

8. A piece of wood that measures 3.0 cm by 6.0 cm by 4.0 cm has a mass of 90.0 grams is placed in a bucket of water.

i) Calculate the density of the wood.

ii) If the density of water is 1.0 g cm^{-3} , will the piece of wood float or sink in water? Explain your reasoning.

9. Classify the following as **physical** or **chemical change**:

- i) Melting of ice.
- ii) Rusting of iron.
- iii) Burning of wood.
- iv) Boiling of water.

10. Give a reason for the following statements:

- i) The density of sea water is higher than the density of tap water.
- ii) Sodium chloride is more soluble in water at 100°C than it is at 25°C .

11. State **one** reason as to why some substances float in water while others sink.

12. A group of students carried out an experiment on **diffusion of gases** as shown below.

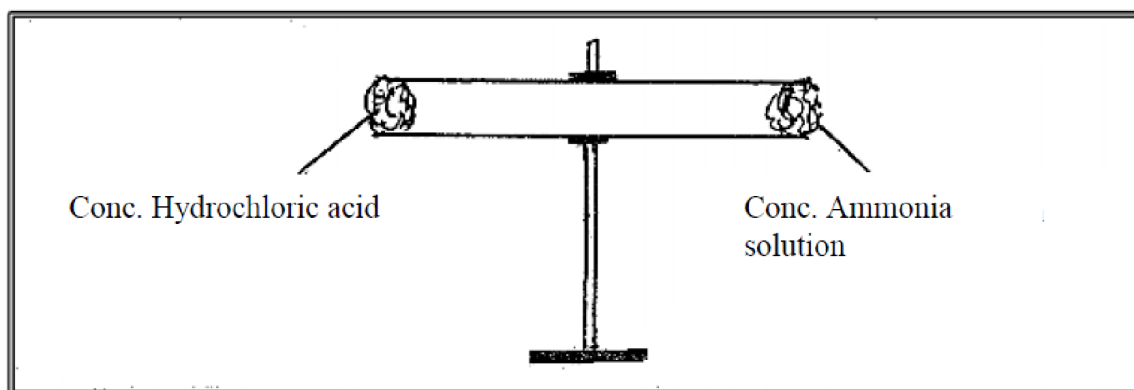

i) State **one evidence** that would show that a chemical reaction has occurred.

ii) Complete the equation for the reaction between ammonia solution and hydrochloric acid.

